



GAUTENG PROVINCE
EDUCATION
REPUBLIC OF SOUTH AFRICA

**GAUTENG DEPARTMENT OF EDUCATION
PROVINCIAL EXAMINATION
NOVEMBER 2019
GRADE 9**

NATURAL SCIENCES

TIME: 1½ hours

MARKS: 80

14 pages

INSTRUCTIONS AND INFORMATION

1. This paper consists of SECTION A and SECTION B, based on the prescribed content in the CAPS document.
2. This paper consists of 14 pages and 9 questions.
3. Answer ALL the questions.
4. Follow the instructions at each question.
5. Number your answers correctly according to the numbering system used in this question paper.
6. Non-programmable calculators may be used.
7. Answer Question 3.2.3 on the attached ANSWER SHEET. Remember to remove the answer sheet from the question paper and to hand it in with your answer script.
8. Write neatly and legibly.

SECTION A**QUESTION 1**

1.1 Various possible options are provided as answers to the following questions. Choose the answer and write only the letter (A–D) next to the question number (1.1.1 to 1.1.10).

1.1.1 What is the unit for the measurement of force?

- A Kilograms
- B Newton
- C Weight
- D Volt

1.1.2 Which of the following forces is a field force?

- A Tension
- B Pull force
- C Magnetic force
- D Compression

Questions 1.1.3 and 1.1.4 refer to the following circuit diagram.

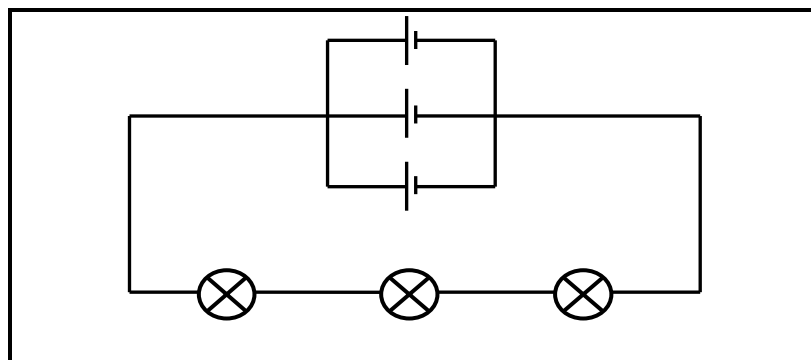

1.1.3 The circuit shows the following:

- A Two cells in parallel and three light bulbs in series
- B Three cells in series and three light bulbs in parallel
- C Three cells in parallel and three light bulbs in series
- D Three cells in series and two light bulbs in parallel

1.1.4 If the potential difference of each cell is 1,5 V, what will be the total potential difference across the battery?

- A 1,5 V
- B 4,5 V
- C 3 V
- D 6 V

1.1.5 Mandy's new hair dryer has only two wires connected to a three-pin plug. A possible reason for this is that ...

- A there is something wrong with the hair dryer.
- B all hairdryers have only two wires.
- C the hair dryer has a plastic cover.
- D NONE of the above-mentioned

1.1.6 The part of the earth that forms the continents is the ...

- A mantle.
- B crust.
- C atmosphere.
- D hydrosphere.

1.1.7 Of how many parts does the earth's core consist?

- A 1
- B 2
- C 3
- D 4

1.1.8 Which of the following minerals cannot be used in its natural form?

- A Potash
- B Sand
- C Gold
- D Diamonds

1.1.9 A possible effect of global warming is ...

- A shorter nights.
- B a rise of the sea level.
- C cooler temperatures.
- D longer days.

1.1.10 The layer of the atmosphere with the lowest density is the ...

- A troposphere.
- B stratosphere.
- C mesosphere.
- D thermosphere.

(10 x 1) (10)

- 1.2 Choose a / an item / word / description from **COLUMN B** that matches a / an item / word / description in **COLUMN A**. Write only the letter (A–G) next to the question number (1.2.1 to 1.2.5).

COLUMN A		COLUMN B	
1.2.1	A huge cloud of gas out of which a star is born	A	Planetary nebula
		B	Red giant
1.2.2	A swollen star at the end of its life	C	White dwarf
		D	The sun
1.2.3	A reaction that changes hydrogen to helium	E	Nebula
		F	Black dwarf
1.2.4	A star of which the centre has contracted	G	Nuclear fusion
1.2.5	A spectacular phenomenon that is lit up by its central white dwarf star		

(5 x 1) (5)

- 1.3 Give ONE word / term for each of the following descriptions. Write only the word / term next to the question number (1.3.1 to 1.3.5).

- 1.3.1 Rock with a high concentration of a valuable mineral
- 1.3.2 The sphere of the earth of which water vapour forms a part
- 1.3.3 The colour of the live wire of a three-pin plug
- 1.3.4 A device used to convert a voltage of 765 kV to 230 V
- 1.3.5 The layer of the earth consisting of rock as well as magma

(5 x 1) (5)

TOTAL SECTION A: 20

SECTION B**QUESTION 2**

- 2.1 The picture below shows a boy busy moving a large carton box by pushing it.



- 2.1.1 Is the force applied by the boy a contact force or a field force? (1)
- 2.1.2 Describe the effect that the force has on the box. (1)
- 2.1.3 What do we call the force between the bottom of the box and the surface of the floor? (1)
- 2.1.4 What will happen to the box if another boy pushes with a force of the same magnitude from the opposite side? (1)
- 2.2 The diagram below shows two charged balls (A and B). Ball A has a positive charge and ball B has an unknown charge.

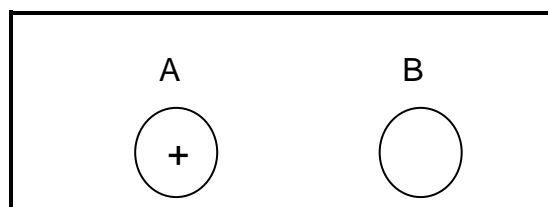

It is determined that the two balls repel each other.

- 2.2.1 What is the charge on ball B? (1)
- 2.2.2 Explain your answer to Question 2.2.1. (2)

[7]

QUESTION 3

3.1 This diagram shows circuits A and B.

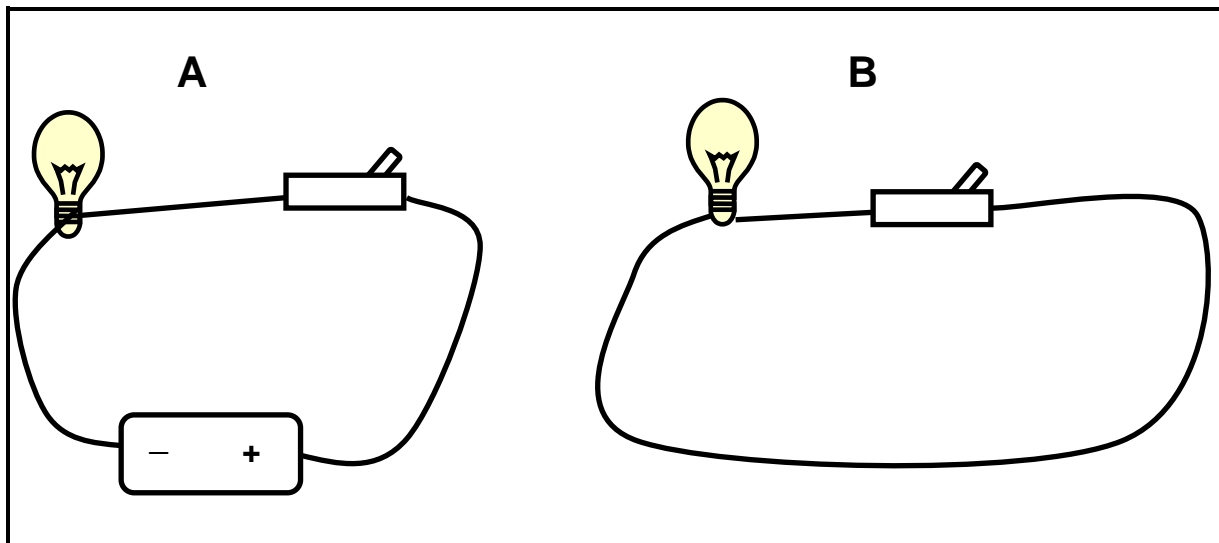

- 3.1.1 Describe your observation when the switch in circuit A is closed. (1)
- 3.1.2 Describe your observation when the switch in circuit B is closed. (1)
- 3.1.3 Give a reason for your observation in Question 3.1.2. (1)

3.2 A group of Grade 9 learners conduct an investigation during which they want to determine the relationship between the length of a conductor and the current strength through the conductor. They use different lengths of the same type of conductor and measure the current strength of the conductors. The following table shows the results of their investigation:

Length of conductor (m)	Current strength (A)
0,1	0,43
0,2	0,36
0,3	0,30
0,4	0,24
0,5	0,18

- 3.2.1 Identify the independent variable. (1)
- 3.2.2 Identify the dependent variable. (1)
- 3.2.3 Use the attached graph paper (ANSWER SHEET) and draw a graph of current strength against length of conductor. (3)
- 3.2.4 Formulate a suitable conclusion for the investigation. (2)

[10]

QUESTION 4

The circuit diagram below shows a battery, three resistors in series (R_1 , R_2 and R_3), and two ammeters (A_1 and A_2). There is a voltmeter connected across the battery, as well as across each of the three resistors. The reading on ammeter A_1 is 2 A. The potential difference across R_1 and R_3 is 1 V each.

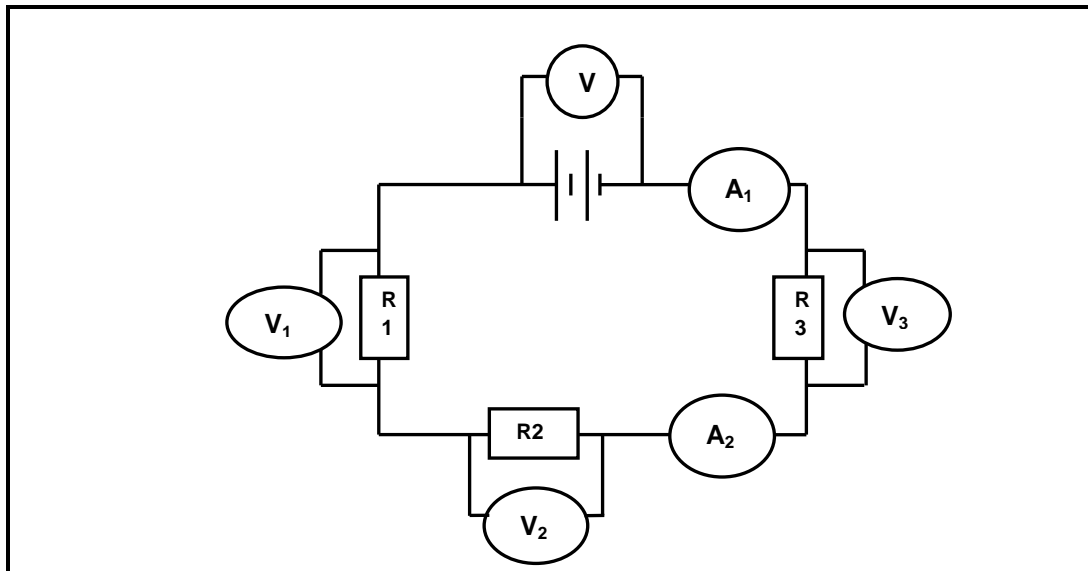

- 4.1 What will be the reading on ammeter A_2 ? Give a reason for your answer. (2)
- 4.2 The reading on the voltmeter across the battery is 4 V. Calculate the reading on the voltmeter across resistor R_2 . (2)
- 4.3 What will happen to the reading on ammeter A_1 in each of the following cases?
(TAKE NOTE: Only write INCREASE, DECREASE or STAYS THE SAME)
- 4.3.1 A third cell, in series, is added to the battery. (1)
- 4.3.2 One of the resistors is removed from the circuit. (1)
- [6]**

QUESTION 5

5.1 Eskom's Koeberg Power Station is the only nuclear power station in South Africa. The following steps are part of the process of generating electricity at such a power station. Arrange the steps in the correct sequence.

- A Steam turns the turbines.
- B Steam is produced through the heating of water.
- C Movement of the turbines drive the generators.
- D Heat is released through nuclear fission.

(TAKE NOTE: Only write the letters in the correct sequence.) (4)

5.2 The following table gives the power rating for a number of household appliances that Sarah has in her house:

Appliance	Power rating (W)
Electric beater	175
Toaster	700
Television	54

5.2.1 Identify the appliance that uses the least amount of energy in an hour. (1)

5.2.2 On a certain day, Sarah uses her toaster for 3 minutes and her electric beater for 30 minutes. Calculate the total cost of electric power usage for the two appliances.

(TAKE NOTE: The unit price is R1,85 per kWh)

Formula: Cost = Power rating x Number of hours x Unit price (8)
[13]

QUESTION 6

In the following diagram the letters A, B, C and D represent the four spheres of the earth:

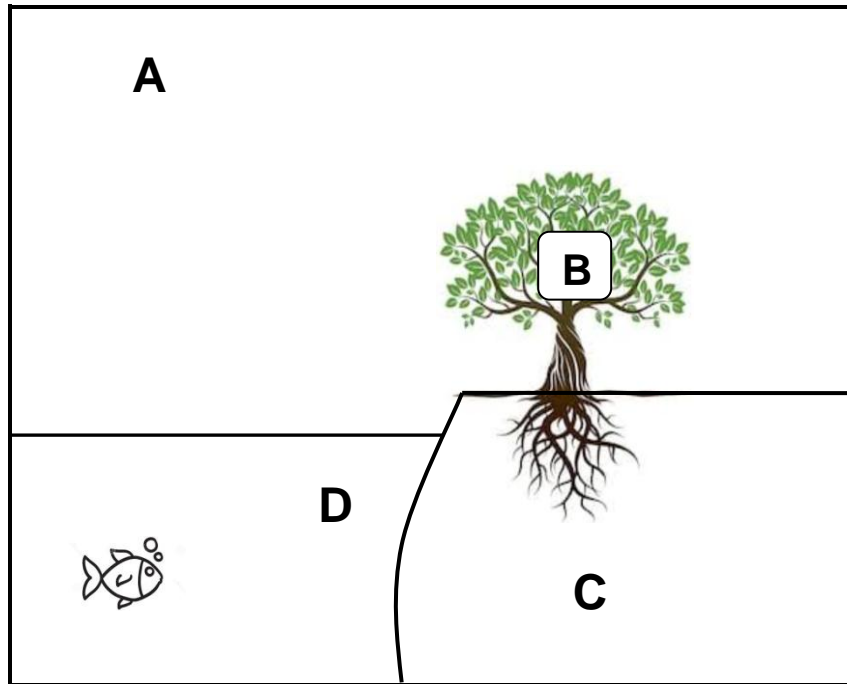

- 6.1 Give the correct term for the sphere represented by the letter D in the diagram. (1)
 - 6.2 Which gas is the most abundant in sphere A? (1)
 - 6.3 Explain the interaction between sphere B and sphere C. (2)
- [4]**

QUESTION 7

Study the following flow chart of the rock cycle and answer the questions that follow.

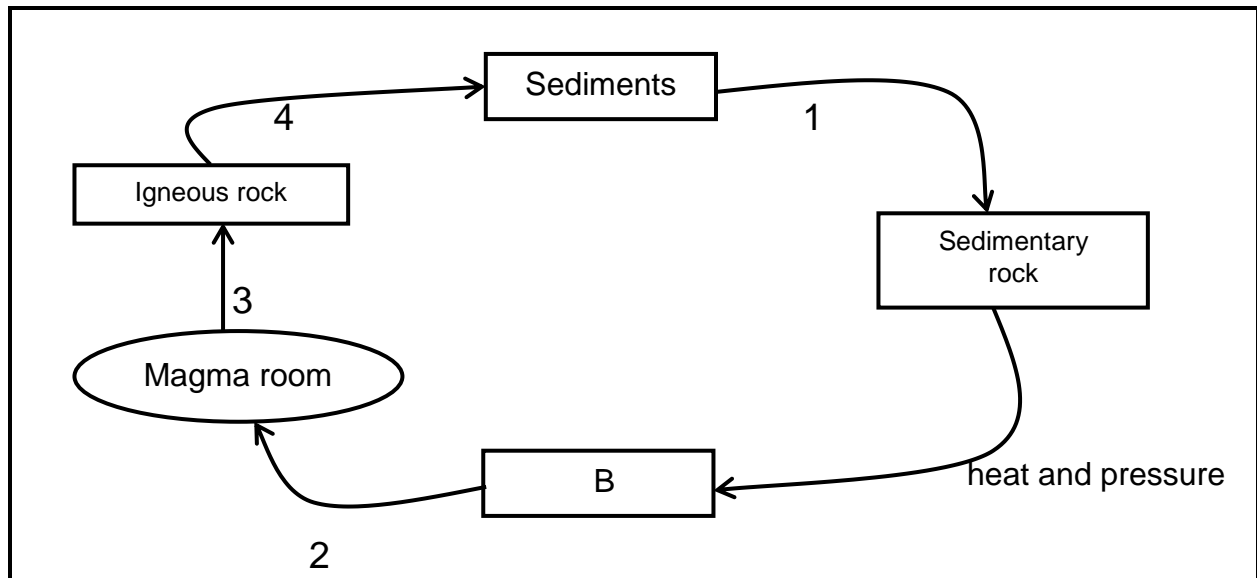

- 7.1 Which type of rock forms at B? (1)
- 7.2 Describe what happens during each of the following processes:
- 7.2.1 Process 2 (1)
 - 7.2.2 Process 3 (1)
 - 7.2.3 Process 4 (1)
- 7.3 Give an example of EACH of the following:
- 7.3.1 Igneous rock (1)
 - 7.3.2 Sedimentary rock (1)
- [6]**

QUESTION 8

The following map shows where minerals are mined in South Africa.

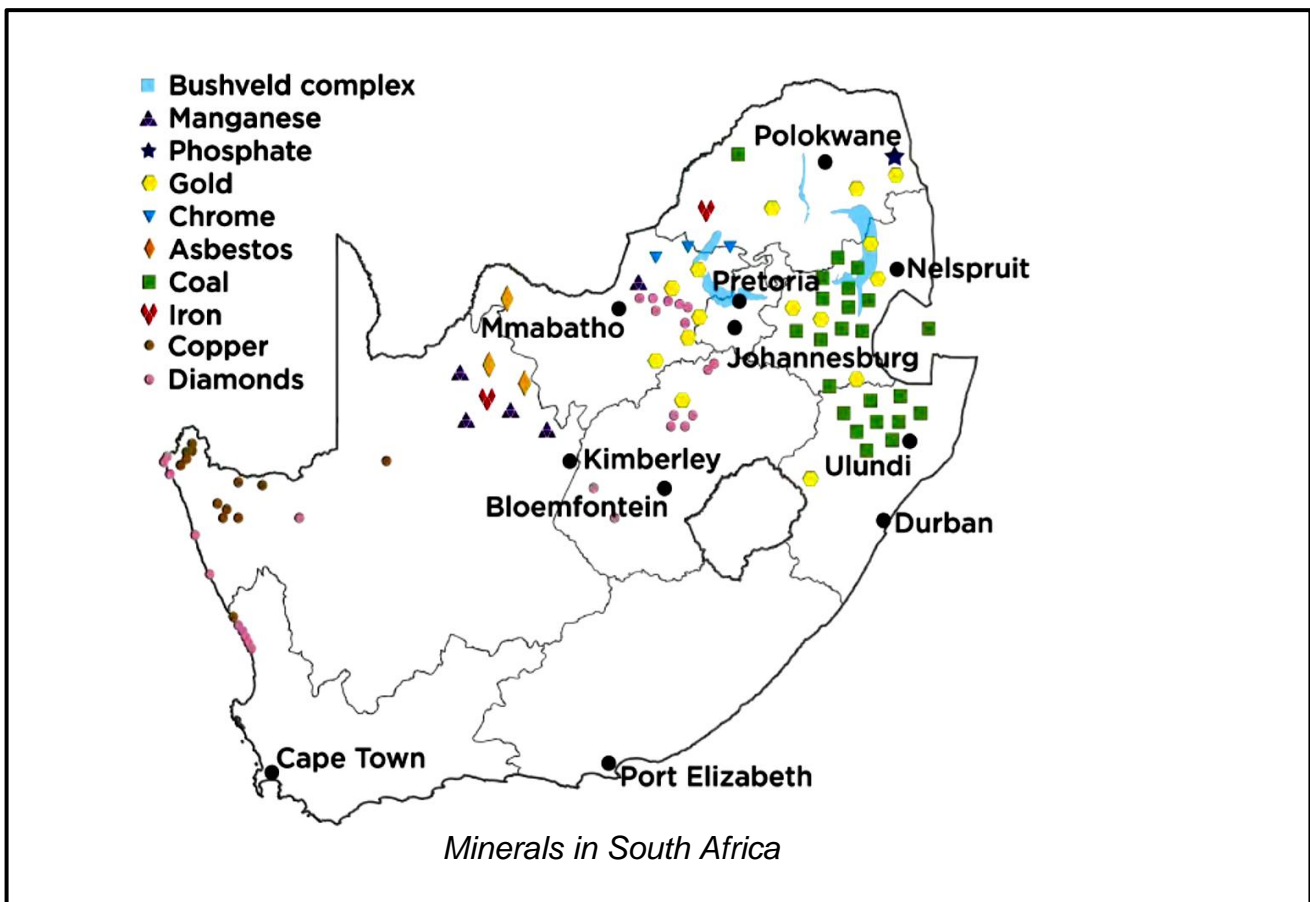

- 8.1 Name ONE mineral being mined on a large scale in South Africa. (1)
 - 8.2 Choose the correct answer within brackets.
Iron is extracted from iron ore through a (physical / chemical) process. (1)
 - 8.3 Explain how steel is manufactured. (2)
 - 8.4 List TWO negative effects of mining. (2)
 - 8.5 In which part of the country is the highest concentration of minerals found? (1)
- [7]**

QUESTION 9

The following graph shows how the temperature changes in the different layers of the atmosphere.

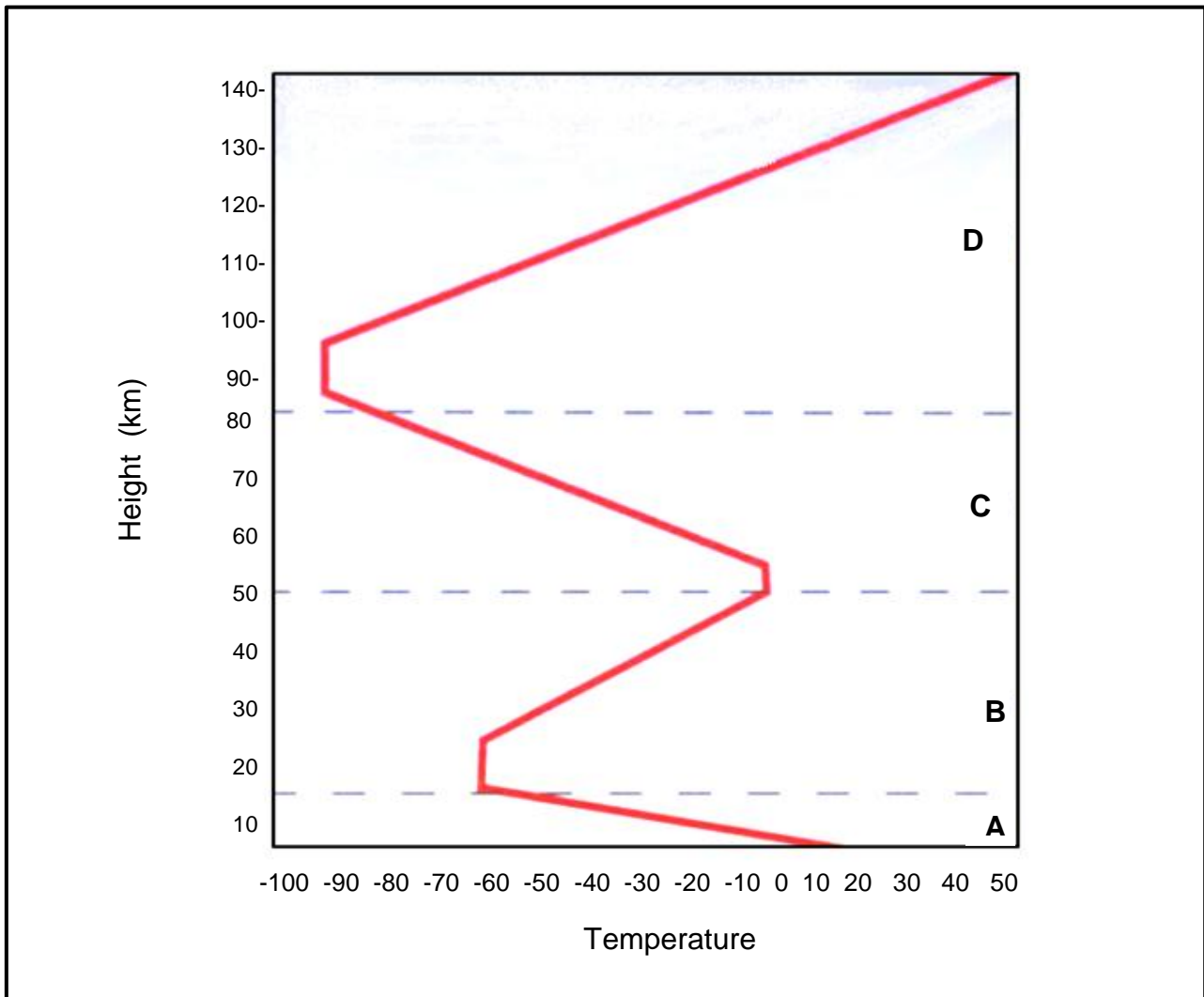

- 9.1 Identify the layers represented by letters **A – D**. (4)
- 9.2 What happens to the temperature in layer C as the height increases? (Only write INCREASE or DECREASE.) (1)
- 9.3 In which layer does weather occur? (Only write **A, B, C** or **D**.) (1)
- 9.4 In which layer can the ozone layer be found? (Only write **A, B, C** or **D**.) (1)

[7]

GRAND TOTAL: 80

ANSWER SHEET

NAME AND SURNAME: _____

QUESTION 3.2.3

The graph of current strength against length of conductor

