



**education**

Department:  
Education  
PROVINCE OF KWAZULU-NATAL

**NATIONAL  
SENIOR CERTIFICATE**

**GRADE 11**

**PHYSICAL SCIENCES P1**

**COMMON TEST**

**JUNE 2019**

**TIME: 2 hours**

**MARKS: 100**

This question paper consists of 15 pages (including a graph sheet for Q 4.3 and an answer sheet for Q 7.2.1). A data sheet is also provided.

**INSTRUCTIONS AND INFORMATION TO CANDIDATES**

1. Write your name on the **ANSWER BOOK**.
2. This question paper consists of EIGHT questions. Answer ALL the questions in the ANSWER BOOK.
3. Start EACH question on a NEW page in the ANSWER BOOK.
4. Number the answers correctly according to the numbering system used in this question paper.
5. Leave ONE line between two subsections, for example between QUESTION 2.1 and QUESTION 2.2.
6. You may use a non-programmable calculator.
7. You may use appropriate mathematical instruments.
8. You are advised to use the attached DATA SHEET.
9. Show ALL formulae and substitutions in ALL calculations.
10. Round off your final numerical answers to a minimum of TWO decimal places.
11. Give brief motivations, discussions, et cetera where required.

**QUESTION 1 : MULTIPLE CHOICE QUESTIONS**

Four options are provided as possible answers to the following questions. Each question has only ONE correct answer. Write only the letter (A - D) next to the question number (1.1 — 1.5) in the ANSWER BOOK, for example 1.6 D.

- 1.1 Two forces A and B of constant magnitude act at the same point as shown below.

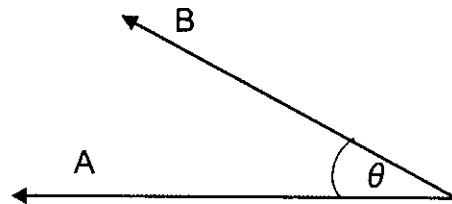

If the angle  $\theta$  increases from  $0^{\circ}$  to  $90^{\circ}$ , the magnitude of the resultant force will .....

- A Increase
  - B Remain the same
  - C Decrease
  - D Increase initially and then decrease
- (2)

- 1.2 The diagram below shows the motion of an object P attached to the ceiling of a railway car.

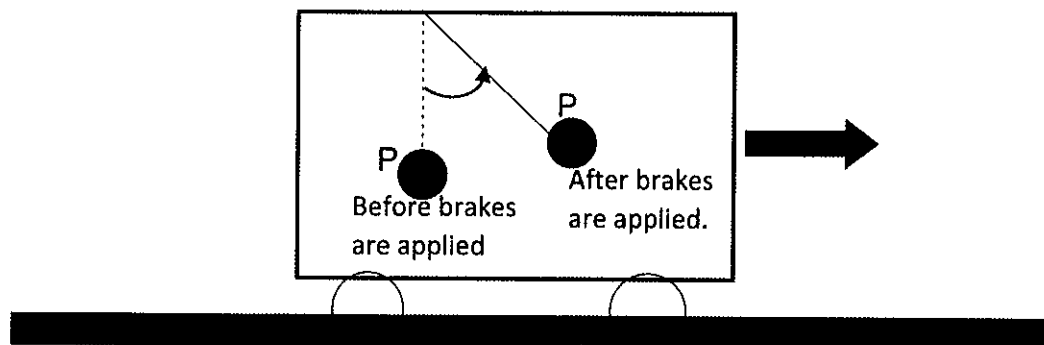

When the brakes are applied it is observed that object P moves as shown above. This motion can best be explained by.....

- A Newton's Second Law
  - B Inertia
  - C Newton's Third Law
  - D Newton's Law of Universal Gravitation
- (2)

- 1.3 The net force versus time graph represents the motion of a car starting from rest on a horizontal surface.

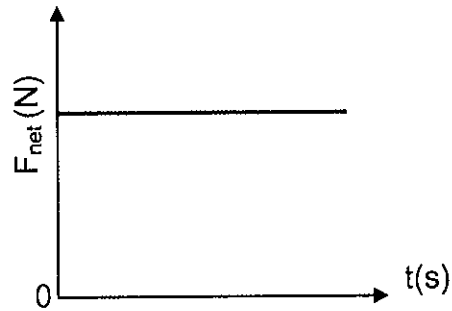

Which one of the velocity-time graphs shown below represents the motion of the car during this period? (2)

A

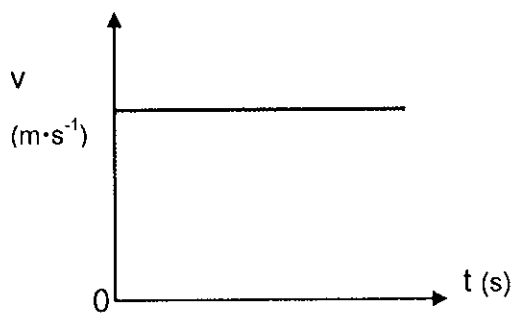

B

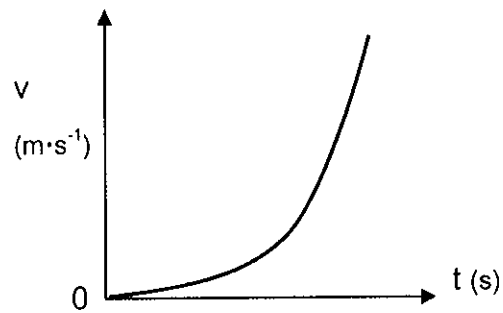

C

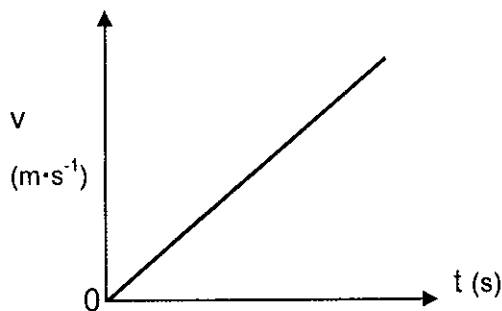

D

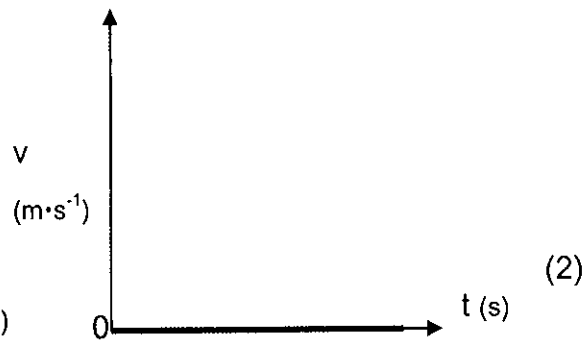

- 1.4 A space rocket of mass  $M$  has a weight  $W$  on the surface of the Earth. The rocket is launched and reaches a height above the surface of the Earth equal to TWICE the Earth's radius. At this height its mass is reduced to a quarter of its original mass ( $M$ ) because it had used up some of its fuel. The gravitational force of attraction between the rocket and the Earth at this height is ....

- A  $12 W$   
 B  $36 W$   
 C  $1/36 W$   
 D  $1/12 W$

(2)

- 1.5 Which ray diagram is the correct representation of the phenomenon of refraction?

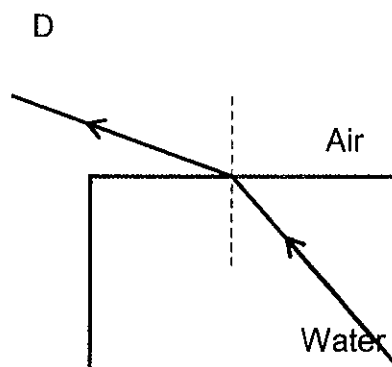
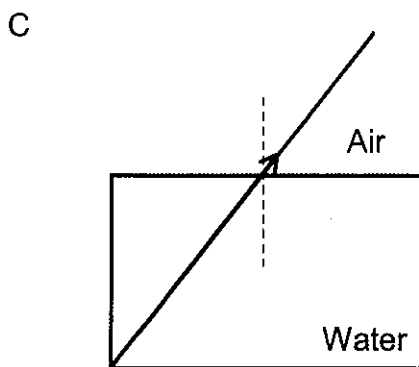
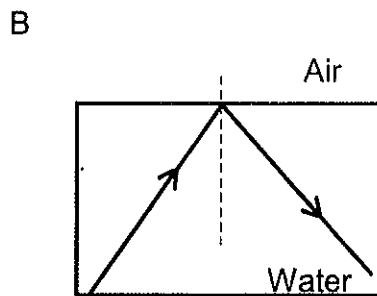
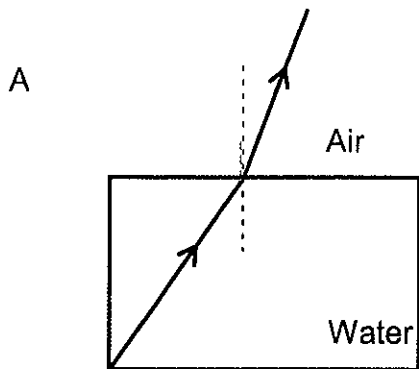

(2)

**[10]**

**QUESTION TWO**

The diagram below shows a body M suspended from a ceiling by string A that is attached to a 2,04 kg mass by string B which runs freely over a pulley. The strings have negligible mass. It is observed that when the system comes TO REST, the angle between strings A and B is  $90^\circ$  and the size of angle x is  $30^\circ$ .

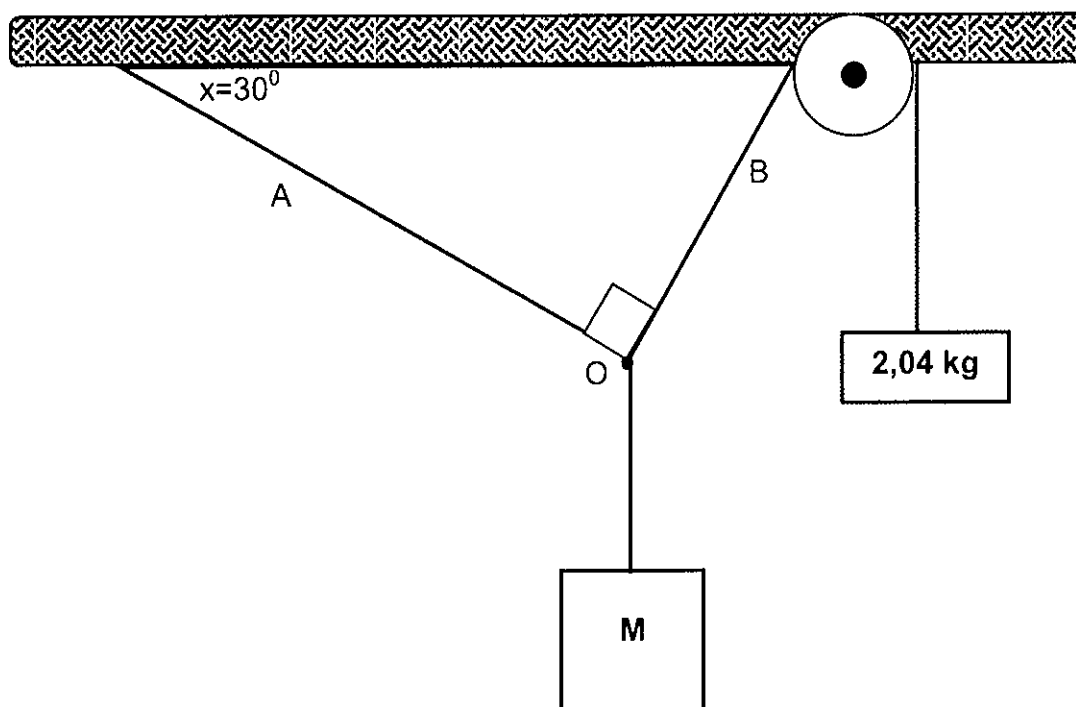

- 2.1 What can be said about the forces acting at point O when the system comes to rest? (2)
- 2.2 Draw a closed vector diagram to show all the forces acting at point O. Indicate two angles in your diagram. (4)
- 2.3 Calculate the mass of body M. (4)

**[10]**

**QUESTION THREE**

A force of magnitude  $F$  is applied to a 100 kg box at an angle of  $60^\circ$  to the horizontal. The box is initially at rest on a rough horizontal surface.

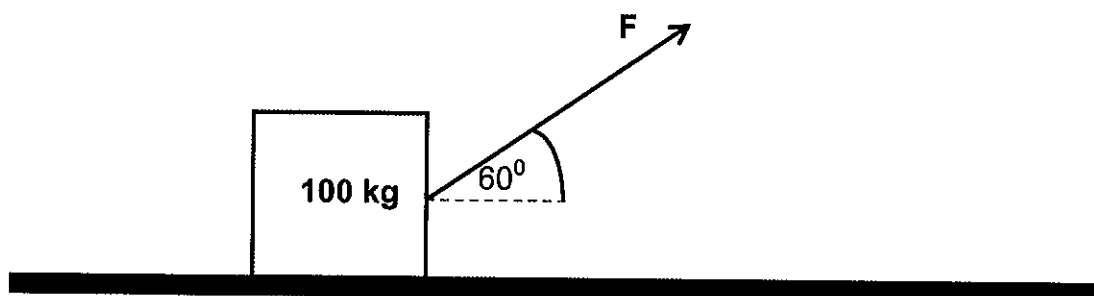

There is a constant kinetic frictional force of magnitude 6,5 N that acts on the box as it moves along the surface. The box moves to the right with a constant acceleration of  $5 \text{ m}\cdot\text{s}^{-2}$ .

- 3.1 State the definition of *kinetic frictional force*. (2)
- 3.2 Calculate the magnitude of force  $F$ . (4)
- 3.3 Draw a force diagram showing all the VERTICAL FORCES acting on the box. (2)
- 3.4 Calculate  $\mu_k$ , the co-efficient of kinetic friction for the box and the surface. (5)
- 3.5 How will the co-efficient of kinetic friction be affected if the angle of the force  $F$  is increased to  $80^\circ$ .  
(Choose from INCREASES, DECREASES or REMAINS THE SAME). (1)

**[14]**

**QUESTION FOUR**

The table below was obtained from an experiment conducted by grade 11 learners. The aim of the experiment was to verify the mass-acceleration relationship of Newton's Second Law.

Mass of trolley(kg)	$\frac{1}{\text{Mass}} \text{ (kg}^{-1}\text{)} \times 10^{-1}$	Acceleration( $\text{m}\cdot\text{s}^{-2}$ )
2	5	4
3	3,3	2.7
4	(a)	1.9
5	(b)	1.6
6	1,7	1.33

- 4.1 Write down the values for (a) and (b) located in the table. (1)
- 4.2 Which variable was kept constant in this experiment? (1)
- 4.3 USE THE GRAPH SHEET PROVIDED to draw a graph of acceleration versus  $\frac{1}{\text{mass}}$ . Draw the line of best fit. (5)
- 4.4 What is the relationship between acceleration and  $\frac{1}{\text{mass}}$ ? (1)
- 4.5 Use your graph to calculate the magnitude of the net force acting on the trolley. (3)

**[11]**



**QUESTION FIVE**

- 5.1 A snowmobile pulls a 50 kg sled down a snowy hill that has a constant incline of  $25^\circ$ . The snowmobile exerts a force  $F$  on the sled.

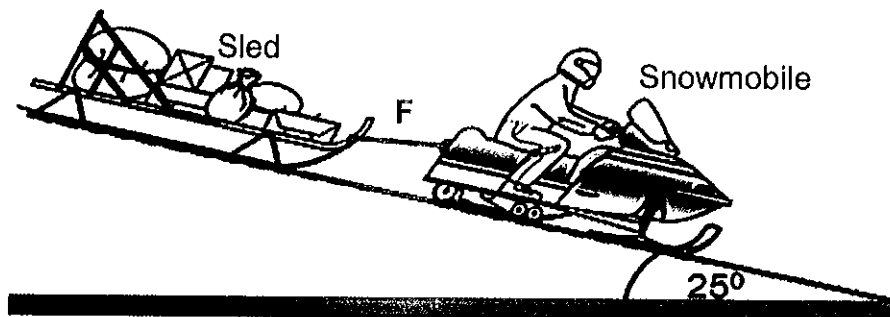

The kinetic frictional force acting on the sled is 17,76 N.

- 5.1.1 State Newton's Second Law of motion in words. (2)
- 5.1.2 Draw a labelled free body diagram to show all the forces acting on the sled. (4)
- 5.1.3 Calculate  $F$  (the force exerted by the snowmobile on the sled) if the sled accelerates at  $5 \text{ m}\cdot\text{s}^{-2}$  down the hill. (4)
- 5.2 Two spheres A and B having masses of  $m$  and 8 kg respectively, are connected by a piece of light, inextensible string. They are pulled vertically upwards by a constant applied force  $P$  of magnitude 200 N. The tension in the string connecting A and B is  $T$ . Ignore the effects of air-resistance.

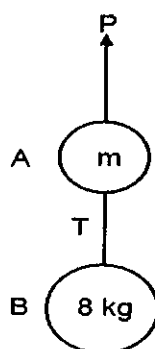

The net force acting on the 8 kg sphere is 40 N.  
Calculate the mass  $m$  of sphere A.

(6)

**[16]**

**QUESTION SIX**

- 6.1 State Newton's Law of Universal Gravitation in words. (2)
- 6.2 Distinguish between the *mass* and the *weight* of an object . (2)
- 6.3 During a lunar eclipse, the Earth, the Moon, and the Sun are aligned on the same plane as shown below

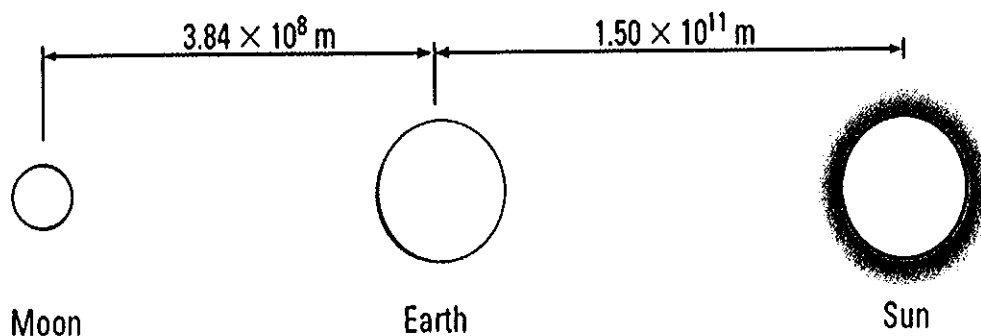
**Data Table**

Celestial Body	Mass (kg)	Mean Separation Distance from Earth (m)
Earth	$5.97 \times 10^{24}$	—
Earth's Moon	$7.35 \times 10^{22}$	$3.84 \times 10^8$
Sun	$1.99 \times 10^{30}$	$1.50 \times 10^{11}$

- 6.3.1 Using the data table given above, calculate the magnitude of the force exerted by the Moon on the Earth. (4)

The force exerted by the Sun on the Earth is  $3.522 \times 10^{22} \text{ N}$ .

- 6.3.2 Write down the magnitude of the force exerted by the Earth on the Sun. (1)
- 6.3.3 Calculate the net force experienced by the Earth due to the Moon and the Sun. (3)

**[12]**

**QUESTION SEVEN**

7.1 State the definition of "refraction of light". (2)

7.2 A ray of monochromatic light having a frequency of  $5.09 \times 10^{14}$  Hz is incident from air to Maize oil to glycerol and strikes a plane mirror. The angle of incidence from air to maize oil is  $35^\circ$  as shown.

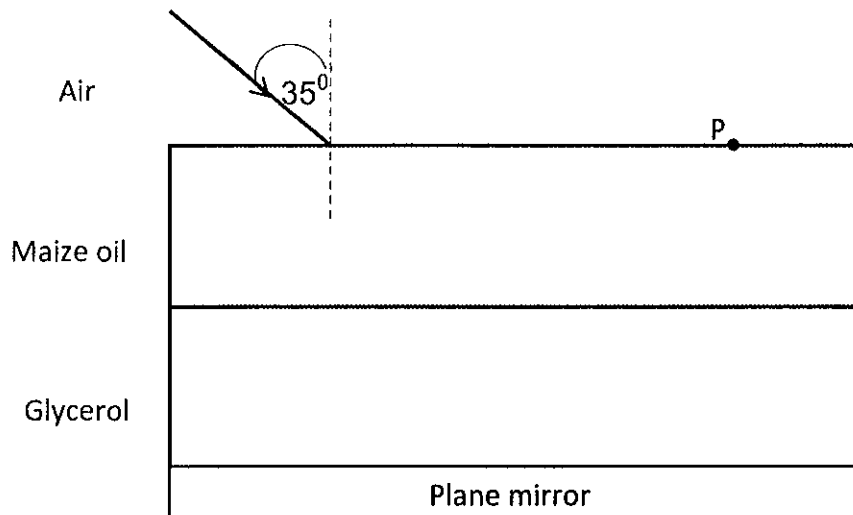

Material	Air	Maize oil	Glycerol
Refractive Index	1,00	1,47	1,47

7.2.1 ***This question must be answered using the answer sheet provided on page 15.***

Draw the path taken by the light ray as it passes :

- From air into the maize oil,
- From maize oil into glycerol
- To strike the mirror and then
- To return to point P.

Draw the normal at each surface. (5)

7.2.2 State Snell's Law in words. (2)

7.2.3 Calculate the angle of the refraction as the ray passes from air to maize oil. (4)

(3)

7.2.4 Calculate the speed of the light ray as it passes through glycerol.  
The speed of light in a vacuum is  $3 \times 10^8 \text{ m}\cdot\text{s}^{-1}$ .

7.2.5 What will be the magnitude of the speed of light as it passes through the maize oil? Give a reason.

(2)

**[18]****QUESTION EIGHT**

The sketch below shows a beam of monochromatic green light passing through a single slit. A pattern is observed on the screen.

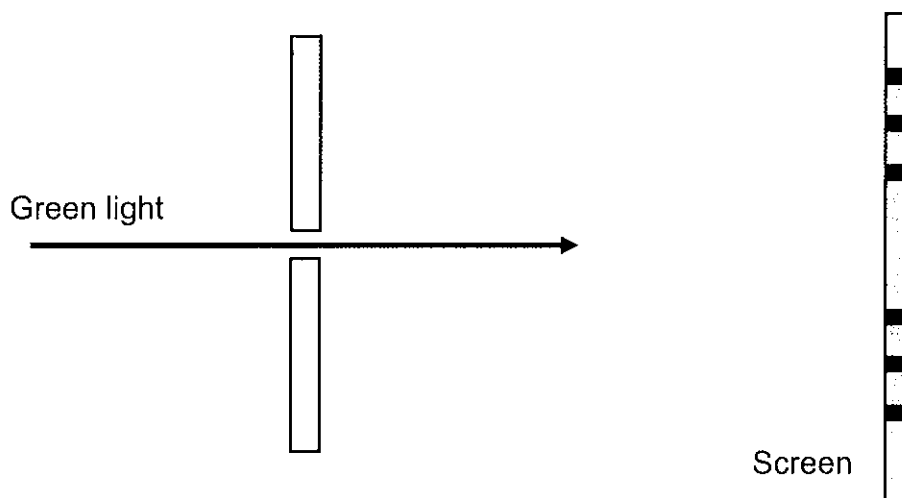

8.1 What do the dark bands represent? Give a reason.

(2)

8.2 What is this phenomenon called?

(1)

8.3 The pattern observed on the screen is explained by Huygen's principle. State Huygen's principle in words.

(2)

8.4 State TWO changes that could be made to the above set up that will affect the appearance of the pattern formed on the screen if green light is used.

(2)

8.5 The green light is now replaced by RED LIGHT. State TWO differences in the pattern that will now be observed on the screen.

(2)

**[9]****[100]**

**Make sure you hand in your answer pages for Questions 4.3 and 7.2.1 with your answer book.**

**DATA FOR PHYSICAL SCIENCES GRADE 11  
PAPER 1 (PHYSICS)**

**GEGEWENS VIR FISIESTE WETENSAPPE GRAAD 11  
VRAESTEL 1 (FISIKA)**

**TABLE 1: PHYSICAL CONSTANTS/TABEL 1: FISIESTE KONSTANTES**

NAME/NAAM	SYMBOL/SIMBOOL	VALUE/WAARDE
Acceleration due to gravity <i>Swaartekragversnelling</i>	g	9,8 m·s <sup>-2</sup>
Gravitational constant <i>Swaartekragkonstante</i>	G	6,67 x 10 <sup>-11</sup> N·m <sup>2</sup> ·kg <sup>-2</sup>
Radius of Earth <i>Straal van Aarde</i>	R <sub>E</sub>	6,38 x 10 <sup>6</sup> m

**TABLE 2: FORMULAE/TABEL 2: FORMULES**

**MOTION/BEWEGING**

$v_f = v_i + a \Delta t$	$\Delta x = v_i \Delta t + \frac{1}{2} a \Delta t^2$
$v_f^2 = v_i^2 + 2a \Delta x$	$\Delta x = \left( \frac{v_f + v_i}{2} \right) \Delta t$

**FORCE/KRAG**

$F_{\text{net}} = ma$	$w = mg$
$F = \frac{Gm_1 m_2}{r^2}$	$\mu_s = \frac{f_{s(\text{max})}}{N}$
$\mu_k = \frac{f_k}{N}$	

**WAVES ,SOUND AND LIGHT/GOLWE, KLANK EN LIG**

$v = f \lambda$	$T = \frac{1}{f}$
$n_i \sin \theta_i = n_r \sin \theta_r$	$n = \frac{c}{v}$



NAME OF SCHOOL : \_\_\_\_\_

NAME OF LEARNER : \_\_\_\_\_ GRADE 11 \_\_\_\_\_

**Question 4.3** Answer sheet

TEAR-OFF SHEET

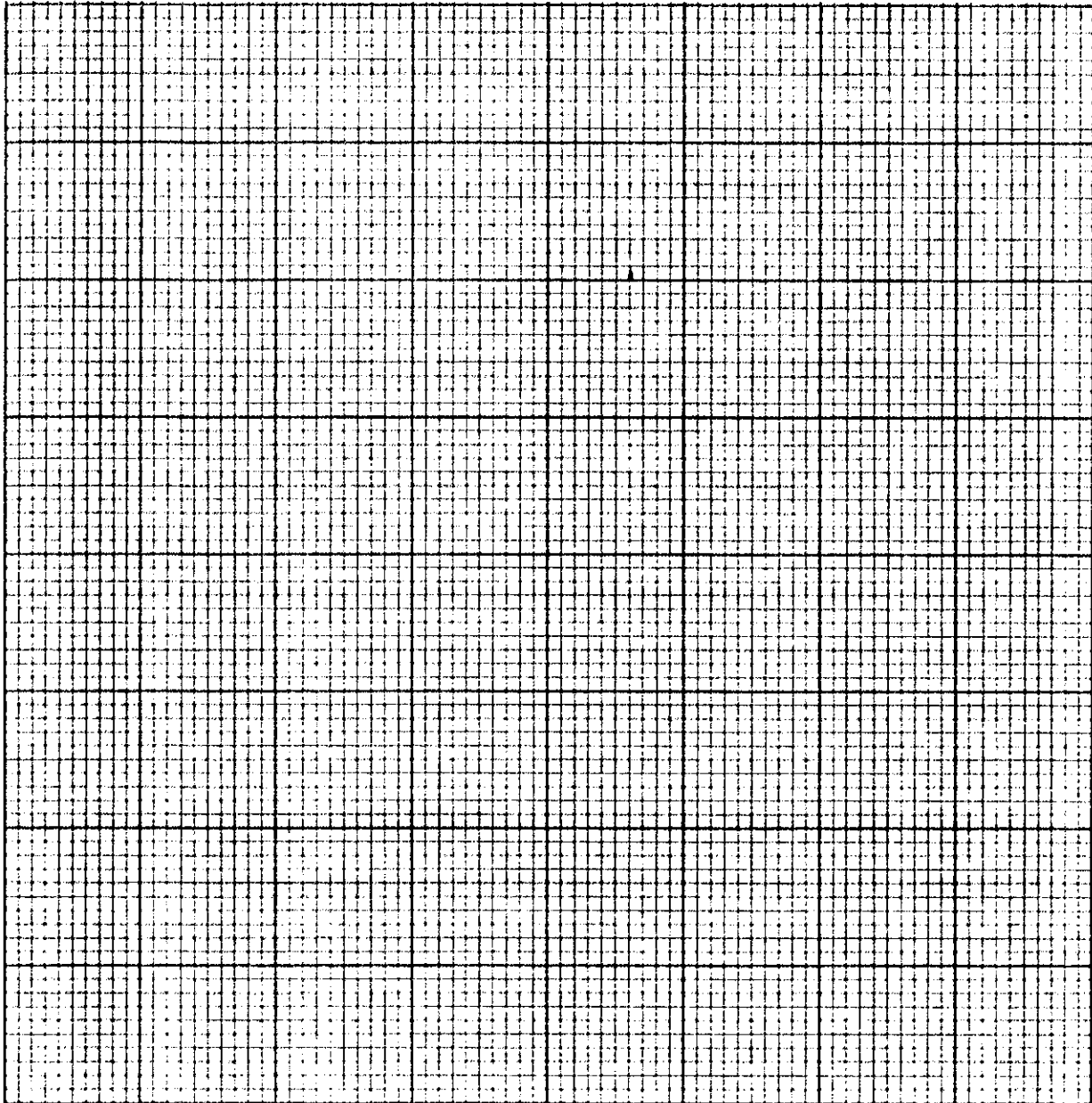

NAME OF SCHOOL : \_\_\_\_\_

NAME OF LEARNER : \_\_\_\_\_ GRADE 11 \_\_\_\_\_

QUESTION 7.2.1 ANSWER SHEET

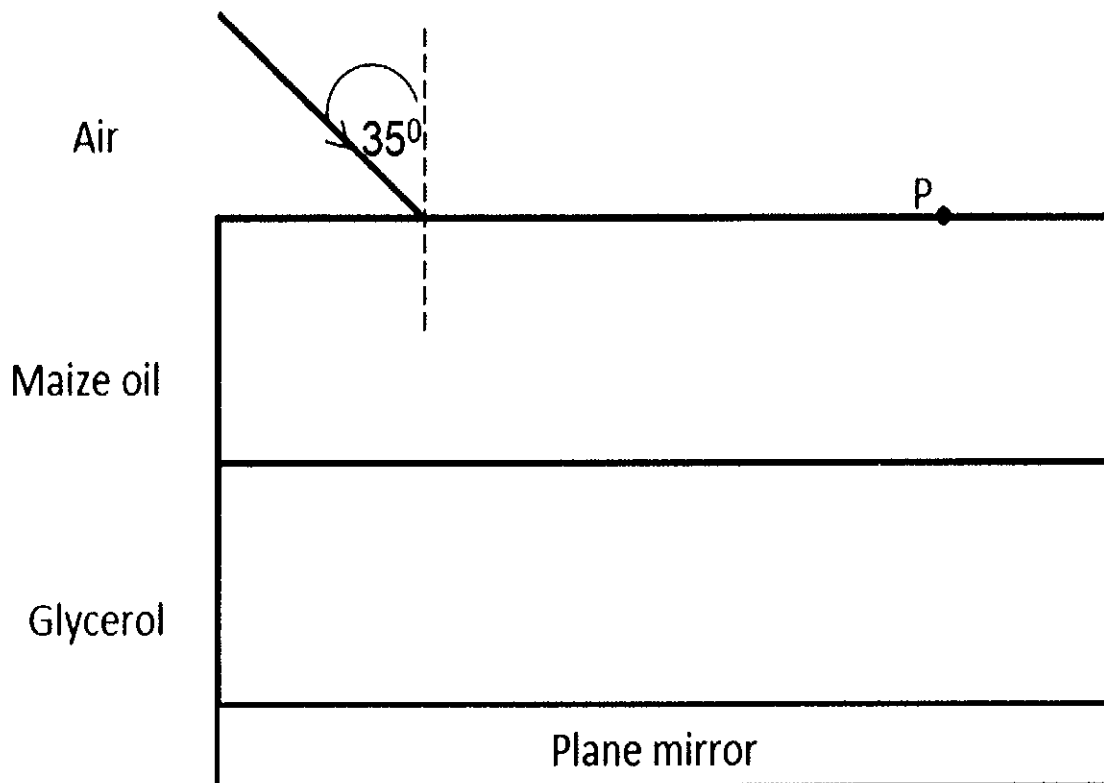

TEAR-OFF SHEET